

SP SERIES SELF PROPELLED AERIAL PLATFORM

KEY FEATURES

- * MOST RIGID MAST
- * MANOEUVRABLE
- * SAFE & COMPACT
- * EXTREMELY VERSATILE PERFORMANCE
- * STABILITY WITHOUT OUTRIGGERS



SP SERIES SELF PROPELLED AERIAL PLATFORM



Specifications	SP 20	SP 25
Working Height	8.0m	9.5m
Platform Height	6.0m	7.5m
Capacity	150kg	125kg
Platform Dimensions	0.69m (L) x 0.64m (W) x 1.13m (H)	
Stowed Dimensions	1.36m (L) x 0.79m (W) x 1.98m (H)	
Ground Clearance	0.05m	
Wheelbase	1.15m	
Turning Radius	0m	
Drive Motor	2 x 24V DC / 0.4kw	
Lifting Motor	24V DC / 2kw	
Drive Speed (Stowed)	4.0km / hr	
Drive Speed (Raised)	1.1km / hr	
Lift / Decend Time	43 / 35 sec	48 / 40 sec
Gradeability	25%	
Batteries	2 x 12V / 120Ah	
Tyres (Drive Motor)	ø230 x 80mm	
Tyres (Front wheels)	200mm (8in)	
Machine Weight	850kg	880kg



STANDARD FEATURES

- Automatic Pothole Protection
- Battery Charge Indicator
- CAN-Bus Technology
- Charger Protection
- Controller Temperature Protection
- Controller Multi Languages Choices
- Emergency Down Button
- Fault Indicator On Platform
- Forklift Pockets
- Horn
- Hour Meter
- Low Voltage Alarm
- Over Loading Protection
- Proportional Controls
- Tilt Alarm
- Tilt Protection
- Two Wheel Drive

OPTIONS

- Extended Platform
- Flashing Beacons

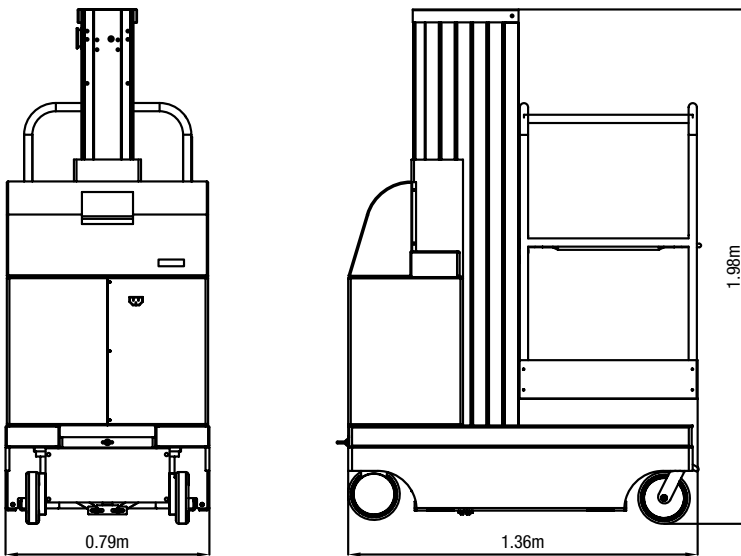

DISTRIBUTED BY:

SOLE AGENT (HONG KONG) :

AVION ACCESS CO. LTD.
恒迅工程有限公司

Unit D, 1/F., Fung Yip Ind. Bldg. 170 Wai Yip St., Kwun Tong, Kowloon, H.K.
 Tel: (852) 2744 2111 Fax: (852) 2796 2882
 info@avion.com.hk www.avion.com.hk

FACTORY :

LEADER 易達 | **廣州藝達**
 GUANGZHOU LEADER EQUIPMENT LTD.

Tan Bu Industrial Park, Tan Bu, Hua Du Qu,
 Guangzhou, Post Code 510820, China
 Tel: (86) 20-8674 7299 Fax: (86) 20-8674 1177 www.leaderlift.cn