

AP SERIES AERIAL PERSONNEL LIFT

KEY FEATURES

- * SAFE & COMPACT
- * VERSATILE PERFORMANCE
- * DURABILITY
- * STABILITY



AP SERIES AERIAL PERSONNEL LIFT

LEADER 易達®

Specifications	AP 20	AP 25	AP 30	AP 36	AP 40	APS 35	APS 40
A Working Height	8.0m	9.4m	10.8m	12.9m	14.1m	12.2m	13.7m
B Platform Height	6.1m	7.5m	9.0m	11.1m	12.3m	10.4m	11.9m
C Stowed Height	1.98m	1.98m	1.98m	2.78m	2.78m	1.98m	1.98m
D Stowed Length	1.24m	1.30m	1.34m	1.40m	1.42m	1.42m	1.48m
E Stowed Width	0.74m	0.74m	0.74m	0.74m	0.74m	0.74m	0.74m
F Tilt-Back Height	1.78m	1.84m	1.89m	1.92m	1.98m	-	-
G Tilt-Back Length	2.11m	2.11m	2.11m	2.97m	2.97m	-	-
H Operation Length	1.54m	1.54m	1.76m	2.12m	2.26m	2.12m	2.26m
I Operation Width	1.34m	1.34m	1.56m	1.91m	2.06m	1.91m	2.06m
J Front Clearance	0.14m	0.08m	0.12m	0.36m	0.37m	0.36m	0.37m
K Side Clearance	0.34m	0.08m	0.44m	0.62m	0.70m	0.62m	0.70m
Platform Dimensions	0.69m (L) x 0.66m (W) x 1.14m (H)						
Capacity	159kg	159kg	159kg	159kg	136kg	100kg	100kg
Weight (AC 220V or 110V)	307kg	330kg	352kg	461kg	472kg	392kg	432kg
Weight (DC Charger + Battery)	348kg	371kg	393kg	502kg	513kg	435kg	475kg

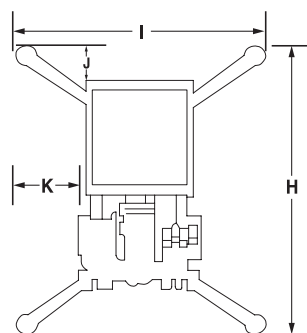
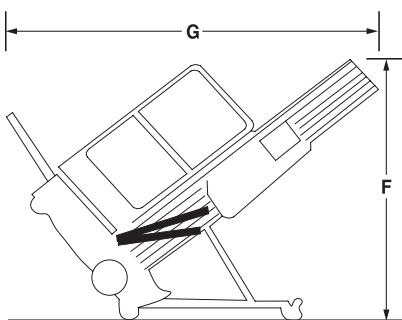
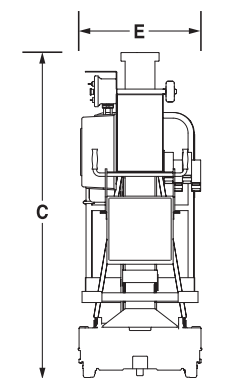
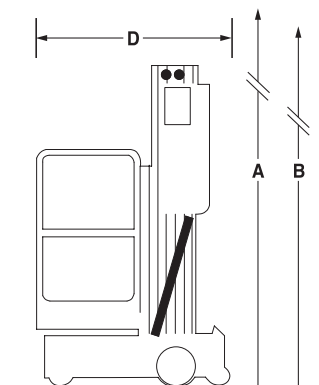

Leader AP Series are designed to meet and exceed ANSI A-92.3 1990, CAS, CE Safety Standard. AP Personnel Lift quick set up, easy control built for maintenance and construction usage.

STANDARD FEATURES

- AC / DC Power Supply
- Locking Key Switch Control Box
- Overhead Crane attachment & Forklift Pockets
- Bubble Level Indicator
- Tilt-Back System for AP 36 & 40

OPTIONS

- Non-Marking Tires
- Descent Alarm & Operation Indicate Lamp
- Tilt-Back System for AP 20, 25 & 30
- Super Straddle to lift 1.02m height & 6° gradient on slope
- Narrow Base & Rough Terrain Base are available for various applications

DISTRIBUTED BY:

SOLE AGENT (HONG KONG) :

AVION ACCESS CO. LTD.
恒迅工程有限公司

Unit D, 1/F., Fung Yip Ind. Bldg. 170 Wai Yip St., Kwun Tong, Kowloon, H.K.
 Tel: (852) 2744 2111 Fax: (852) 2796 2882
 info@avion.com.hk www.avion.com.hk

FACTORY :

LEADER 易達® | **廣州藝達**
 GUANGZHOU LEADER EQUIPMENT LTD.

Tan Bu Industrial Park, Tan Bu, Hua Du Qu,
 Guangzhou, Post Code 510820, China
 Tel: (86) 20-8674 7299 Fax: (86) 20-8674 1177 www.leaderlift.cn